

*OLD TELEPHONES*

*How to Repair and  
Rebuild Them*

by

Jeffrey Race

Version 2.0 July 29, 2000

Copyright © 1972, 2000

by

Jeffrey Race

Cambridge Electronics Laboratories  
20 Chester Street  
Somerville, Massachusetts 02144 USA

Telephone +1 617 629-2805      Telefax +1 617 623-1882  
camblab@attglobal.net                      www.camblab.com

This is a revised version of a text first published in 1972. It may be reproduced without permission for any non-commercial purpose, provided the entire text and attribution, including this notice, is included and such reproduction is advised and a copy furnished to the copyright owner.

Reproduction for any commercial purpose in any form requires written permission of the copyright owner; contact as above.

Cambridge Electronics Laboratories manufactures the *Black Magic*<sup>™</sup> Telephone Ringing Generator and the *Quiklink Private Wire*<sup>™</sup> Automatic Ringdown Unit, used for testing and demonstrating telephone equipment. For details refer to <www.camblab.com>.

## Table of Contents

Introduction	1
Magneto telephones	1
Common battery manual telephones	7
Common battery dial telephones	10
Converting magneto sets to common battery operation	14
Suggested suppliers	16
Resources	17
Registration form to receive literature updates	18

## List of Figures

Figure 1	Basic magneto wall telephone circuit	2
Figure 2	Alternate magneto wall telephone circuit	2
Figure 3	Candlestick circuit	4
Figure 4	Cradle circuit	4
Figure MR	Magneto ringer box	4
Figure 5	Basic common battery manual circuit	7
Figure 6	Common-battery candlestick circuit with separate ringer box	8
Figure 7	Common-battery candlestick circuit	8
Figure 8	Common-battery cradle circuit	8
Figure SI	WE sidetone ringer box	8
Figure 9	WE manual anti-sidetone candlestick circuit	9
Figure 10	WE manual anti-sidetone cradle circuit	9
Figure AS	WE 634A anti-sidetone ringer box	9
Figure 11	WE 553A wall phone ("hotel phone")	10
Figure 12	WE dial candlestick circuit	10
Figure 13	Ericsson dial candlestick circuit	11
Figure 14	WE 202 cradle set, wired for sidetone circuit	11
Figure 15	WE 202 cradle set, wired for sidetone circuit with AE dial	11
Figure 16	WE candlestick set wired for anti-sidetone circuit	11
Figure 17	WE cradle set wired for anti-sidetone circuit	12
Figure 18	WE or other manufacturer cradle instrument wired for anti-sidetone circuit using AE dial	12
Figure HS	Hookswitch spring modification	15

[This page intentionally left blank]

## INTRODUCTION

Up until the early 1960s America's heritage of early telephones was largely ignored by collectors. Unusual, carefully crafted old telephones were discarded as "old-fashioned". Now, however, a new awareness of the values of the past has developed, and collectors have turned so avidly to telephones that many fascinating early models are practically unavailable.

Collecting telephones is a rewarding hobby, not just because of the charm of early instruments, but also because the phones themselves can be adapted to operate on modern circuits, doubling the enjoyment of the collector. (However, check local regulations before connecting an instrument to company lines.)

This booklet is intended for hobbyists who wish to restore early phones and preserve them for future generations to enjoy. It describes the theory of operation of various types of instruments, repair of damaged instruments, replacement of substandard or defective parts, and adaptation of early magneto and manual instruments to work on modern dial systems. No more is required than a knowledge of basic electrical circuits, hand tools, a soldering iron, perhaps a voltmeter, and enthusiasm. Those unfamiliar with the circuit symbols employed here should refer to a text on electrical fundamentals, available at any local library.

## MAGNETO TELEPHONES

### **Theory of operation**

Magneto telephones were the first widespread type of instrument. They derive their name from the use of a magneto (small hand generator) to develop an alternating current of about 100 Volts to signal the other party or operator. The advantages of magneto circuits are simplicity, ruggedness, and ability to operate over long and poor-quality lines. The disadvantages are the requirement of separate batteries at each location (hence the use of the term "local battery" to describe magneto instruments) and inefficient switchboard use.

The basic diagram of a magneto phone is given in Figure 1, and a slight variant in Figure 2. There are three parts: the talking circuit; the receiving circuit; and the signalling circuit.

### ***Talking circuit***

The talking circuit consists of the transmitter (microphone), the hook-switch, the primary of the induction coil (transformer), and the battery. The transmitter is a carbon microphone, composed of loosely packed carbon granules affixed to a metal (later a fiber or impregnated cloth) diaphragm. The diaphragm vibrates in response to the sound waves from the speaker's voice, alternately compressing and releasing the carbon granules, thereby varying

their resistance. The varying current produced, flowing through the primary of the induction coil, induces a current into the secondary, which is carried by the line (connected to  $L_1$  and  $L_2$ ) to the receiver of the distant party.

The purpose of the hookswitch is to interrupt the battery current when the instrument is not in use, extending the life of the battery.

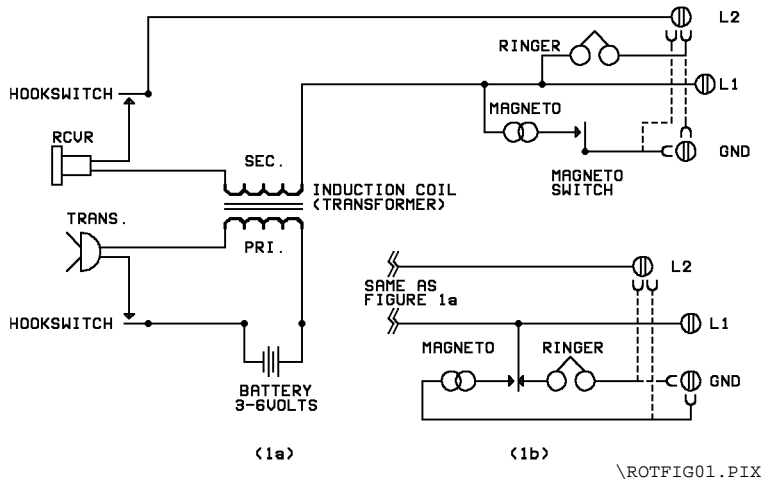

Figure 1: Basic magneto wall telephone circuit

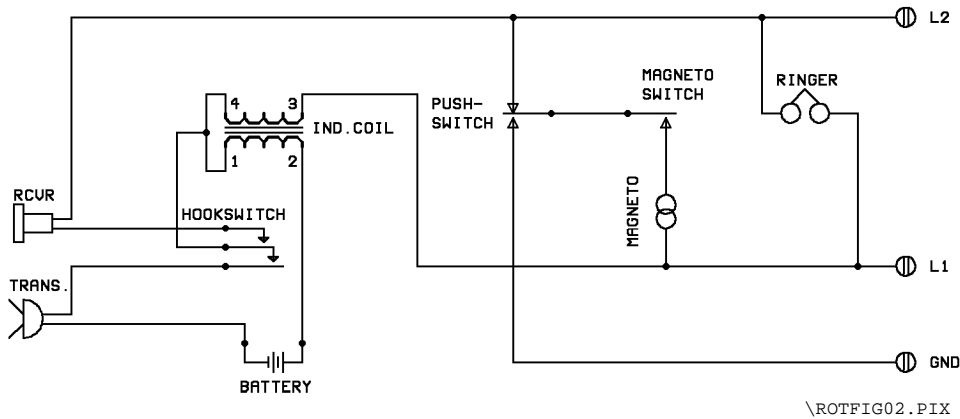

Figure 2: Alternate magneto wall telephone circuit (redrawn from Northern Electric diagram). Note the addition of the pushbutton, which permits the user to ring either the switchboard or other parties.

### **Receiving circuit**

The receiving circuit consists of the receiver (earphone), secondary of the induction coil, hookswitch, and external line. The receiver is a diaphragm of magnetic material, separated by a small distance from the permanent magnet which is also the core of a winding of fine-gauge wire. Alternating current reaching the receiver from the external line, through the induction coil and hookswitch, varies the magnetic field produced by the permanent magnet core, setting the diaphragm in motion to reproduce the sound waves impinging on the transmitter diaphragm of the distant telephone.

The purpose of the hookswitch in the receiver circuit is to remove the phone from the line when not in use. Were this not done, energy would be absorbed by the transmitter and receiver circuits, diminishing the power received by other instruments on the line, and interfering with the ringing signals.

### **Signalling circuit**

The signalling circuit consists of two parts: the magneto and the ringer. When cranked the magneto generates 80 to 100 Volts a.c., at about 20 Hertz (cycles per second). It also contains a switch which disconnects the magneto from the circuit when not being cranked (possibly thereby connecting the ringer--see Figure 1b).

The ringer is a bell resonating at 20 Hertz with a high impedance at voice frequencies to prevent loss of talking power.

There are several possible configurations of the signalling circuit. One method (solid lines in Figure 1a) shows the ringer connected across the two line wires, and the magneto connected from  $L_1$  to ground. The distant instrument in such a system (or the switchboard) would use the configuration shown by the dashed lines. In this way one party rings the other across the line wires, and the other rings the first from  $L_1$  to ground. Thus neither rings his own bell.

An alternative is shown in Figure 1b. Here the magneto switch disconnects the bell when the magneto is cranked. The solid lines thus are identical to the circuit shown in Figure 1a. However, if the movable magneto wire is transferred from ground to  $L_2$ , the system is adapted to a multi-party line (i.e. one without switchboard). Any party can ring all other parties, while not ringing his own bell. Each instrument is then wired identically.

### **Candlestick and cradle instrument circuits**

The basic circuit shown in Figures 1 and 2 is used in wall-mounted magneto phones having a separate transmitter and receiver. Later types used a candlestick instrument with a separate wall-mounted ringer box, and still more "modern" types used a cradle phone with separate ringer box. The circuit for the former is shown in Figure 3 and for the latter in Figure 4. Theory of

operation is identical for each, the major difference being in the hookswitch configuration.

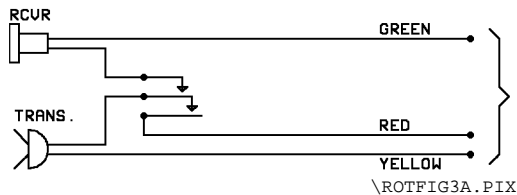

Figure 3: Candlestick circuit; use with wall-mounted ringer box at right

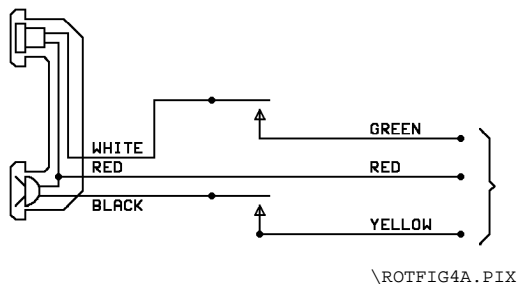
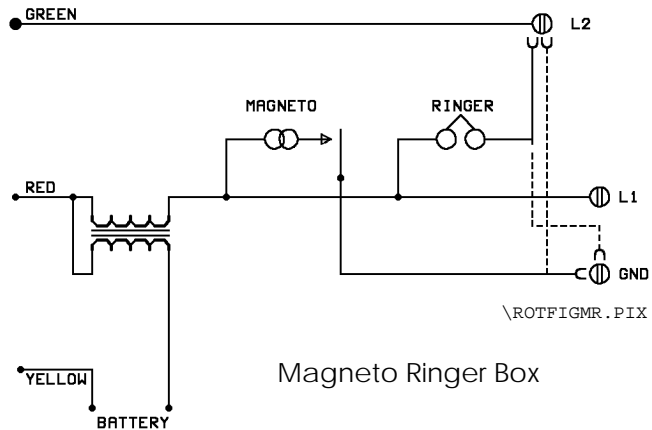

Figure 4: Cradle circuit; use with wall-mounted ringer box at right



Magneto Ringer Box

## Rebuilding and troubleshooting

Magneto instruments may be checked out and improved for operation on magneto lines as follows.

### *Talking circuit*

Old-style carbon granule transmitters can still be used, but verify that they are not open; resistance should measure between 50 and 300 ohms. However, more clarity can be obtained by replacing old-style transmitters with new "capsule" units used in modern telephones. Either F-1 units (2-1/4 inches in diameter) or T-1 units (1-3/4 inches) may be used, depending on space. Electret units, providing even greater clarity, are packaged in T-1 form and sold by Walker Equipment and others for G-style handsets. The even smaller N-1 units, only 1-1/4 inches in diameter, are sold by Roanwell as Model 200 for use in Model 52 operator sets. Leads should not be soldered to their terminals due to the risk of heat damage; instead utilize electrically conductive epoxy.

European-style desk and wall phones with "French" handsets have less internal space for the transmitter, which may be replaced if necessary with the above-mentioned N-1 unit. Care should be exercised in removing the front cap of such transmitters: in certain units the carbon granules are loose and will spill out if the handset is not held with the transmitter opening upward during disassembly.

The induction coil should also be checked for continuity if the phone is not working. The primary should measure between one and four ohms and the secondary between 10 and 40 ohms.

Defective cords are a common source of trouble on old phones. Resistance of each wire should be no more than five ohms and should not vary when the cord is flexed.

### ***Receiving circuit***

Common difficulties are accumulation of dirt between the diaphragm and magnet faces on long-pole receivers; too little or too much gap; loss of magnetism; or open coils. Units can be checked by temporarily substituting a receiver from a modern instrument; if there is a substantial difference in volume, a new receiver can be purchased.

Remember in replacing or remounting cords to anchor the cord in such a way as to provide a strain relief.

Low-volume capsule or non-capsule receivers in handset instruments can usually be replaced by an HC-3 capsule receiver, only 1-9/16 inches in diameter. (See rear of this booklet for suggested suppliers of these parts.)

### ***Signalling circuit***

Bells can be checked for continuity--coil resistance should measure a few hundred to a thousand ohms. A common difficulty is accumulation of dirt or magnetic filings between the magnet cores and the armature which moves the clapper.

Magnetos should produce between 80 and 100 V. Failure may be due to an internal open circuit or simply to dirty or improperly gapped contacts on the switch which connects the magneto when cranked.

Please complete registration form on page 18 to receive  
product and literature updates.

## COMMON BATTERY MANUAL TELEPHONES

### Theory of operation

Common battery systems permit more efficient switchboard use because the Central Office can detect automatically whether an instrument is off the hook. This is indicated by a complete direct current path through the transmitter circuit, and so there is no need to "ring off" as on magneto systems. In addition, transmission quality is higher because an assured talking current is provided all instruments from the Central Office. The price, however, is the need for a better quality line and more complex switching equipment.

There are two types of common-battery circuits: sidetone and anti-sidetone. Sidetone is the sound in the receiver of the speaker's own voice, which can interfere with communication if the speaker is in a noisy location. Anti-sidetone circuits, introduced later, reduce the sidetone.

The basic sidetone circuit is shown in Figure 5.

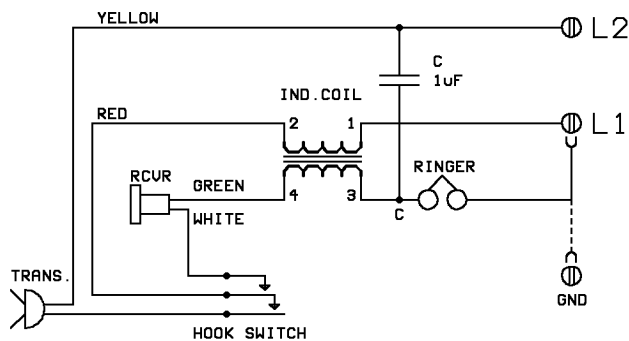

ON SOME UNITS IND. COIL MAY BE MARKED 1=L1, 2=R, 3=C, 4=GN

\ROTFIG05.PIX

Figure 5: Basic common battery manual circuit  
(drawn from WE wall phone ["hotel phone"])

### Talking circuit

When the hookswitch is closed, the first contact to make completes a circuit from  $L_2$  through the transmitter and induction coil primary back to  $L_1$  and the Central Office. The low d.c. resistance of the instrument (200 to 300 ohms) operates a relay in the Central Office, flashing a light on the switchboard. Talking power is provided from the same source.

### Receiving circuit

The last contact to make on the hookswitch completes the receiver circuit through the transmitter, capacitor (condenser in earlier terminology), and secondary of the induction coil. Voice current from the distant party induces a current in the secondary which is heard in the receiver. The capacitor prevents direct current from passing through the receiver, which might weaken its permanent magnet.

### Signalling circuit

As with the magneto system, ringing may be either bridged (from  $L_1$  to  $L_2$ ) or divided (from one line to ground). In the bridged circuit, used on private lines, the solid ringer connection in the schematic diagrams is used. In the divided circuit, used on party lines, employ the wiring shown in the dashed connections. The capacitor performs double duty by also preventing

line current from flowing through the ringer, giving the Central Office a false indication of off-hook condition.

If ringing is not desired, simply disconnect the two ringer leads and tape.

**Candlestick and cradle instrument circuits**

Figures 6 and 7 illustrate different manufacturers' basic circuits for the candlestick instrument, while Figure 8 illustrates a cradle phone circuit.

Note that sidetone circuits require only a three-conductor cord from desk instrument to wall box. Note also that *all* common battery instruments require an induction coil (either in the phone or on the wall). Simply wiring transmitter and receiver in series will destroy the receiver magnets in time.

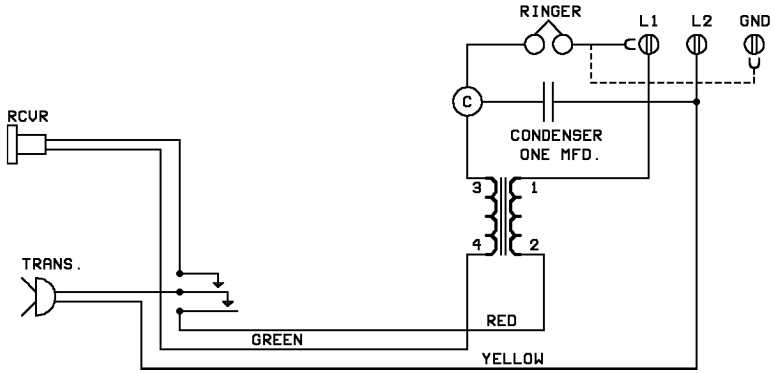

\ROTFIG06.PIX

Figure 6: Common battery candlestick circuit with separate ringer box (drawn from 1926 Kellogg desk set)

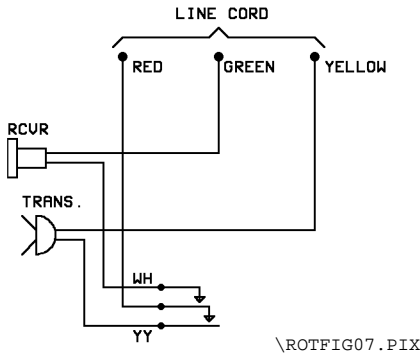

\ROTFIG07.PIX

Figure 7: Common battery candlestick circuit (drawn from early WE desk set)

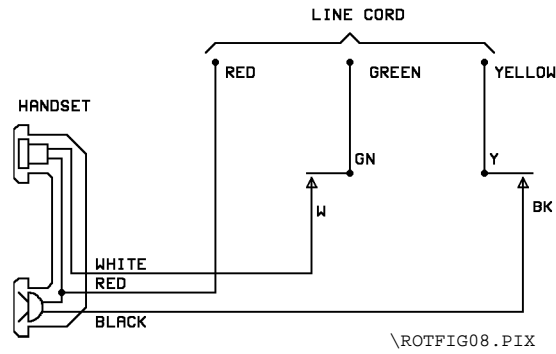

\ROTFIG08.PIX

Figure 8: Common battery cradle circuit (drawn from WE 202 desk set)

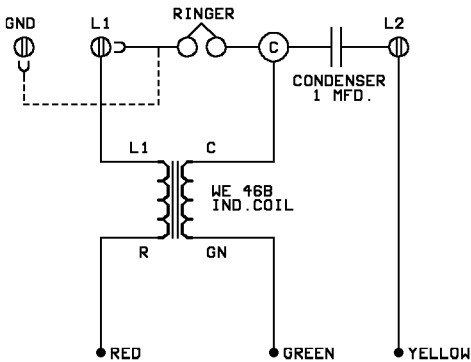

\ROTFIG04.PIX

AT LEFT: Circuit of WE 634A ringer box with 46B induction coil; for use with the two above circuits

This is a sidetone ringer circuit.

## Anti-sidetone circuits

Figures 9 and 10 illustrate two Western Electric anti-sidetone circuits. The major differences from the sidetone circuits are:

1. an additional winding in the induction coil, which provides an induced voltage counter to that set up by the local transmitter, cancelling out part of the sidetone;
2. a different hookswitch arrangement;
3. an additional capacitor;
4. a four-conductor cord.

Western Electric anti-sidetone induction coils are numbered 146B and 101B. Other manufacturers' units may be checked to determine whether they contain the additional winding by measuring the resistance between the 1-2 and 3-4 ( $L_1$ -R and C-GN) windings. If open, it is a sidetone coil; if a low resistance (indicating the additional winding) it is an anti-sidetone coil.

It should be noted that ringer boxes containing an anti-sidetone induction coil can be used *only* with candlestick and cradle instruments having a four-conductor line cord and two separate parts to the hookswitch (e.g. Figure 9 as opposed to Figure 7). On the other hand, ringer boxes with sidetone induction coils may be used with anti-sidetone-wired candlesticks and cradle instruments by omitting the black cord connection at the ringer box and wiring as a sidetone unit. Otherwise any manufacturer's ringer boxes and instruments may be intermixed so long as the components conform to the circuits shown.

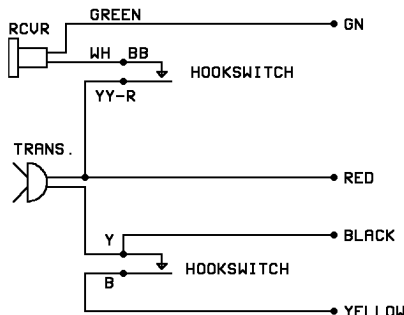
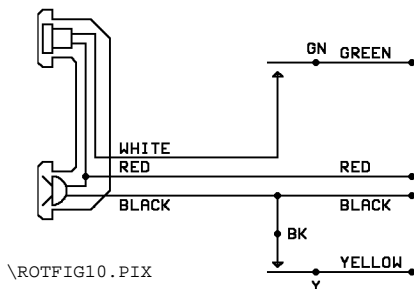

Figure 9 (left): WE manual anti-sidetone candlestick circuit

Figure 10 (below left): WE manual anti-sidetone cradle circuit

Below right: WE 634A ringer box with 146B or 101B anti-sidetone coil (use with circuits in Figures 9 and 10)

\ROTFIG09.PIX



\ROTFIG10.PIX

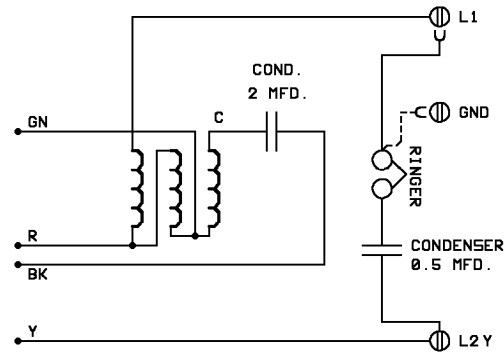

## Rebuilding and troubleshooting

Transmitter, receiver and bell may be rehabilitated as noted under magneto circuits. Common battery induction coils should measure between 10 and 20 ohms in each winding.

### COMMON BATTERY DIAL TELEPHONES

#### Theory of operation

Addition of a dial to a common battery manual instrument permits automatic operation of Central Office equipment. The dial consists of two sets of springs (metal leaf contacts):

1. pulsing springs: these interrupt the complete d.c. path through the instrument a number of times corresponding to the digit dialed (10 times for "0" in the United States and in most other countries);
2. shunting springs: these short out the rest of the instrument while pulsing in order to provide squarer pulses to the dial equipment and in order to prevent unpleasant clicks in the receiver. (Western Electric dials open the receiver circuit instead of shunting it.)

Figures 11 through 18 provide typical circuits for various manufacturers.

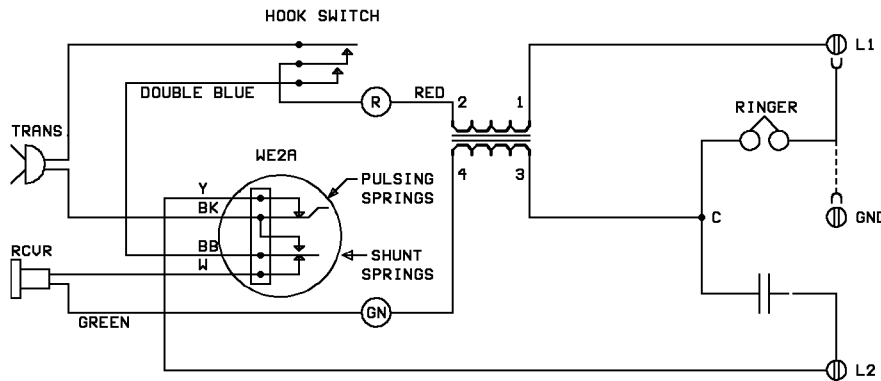

Figure 11: WE 553A wall telephone ("hotel phone")

\ROTFIG11.PIX

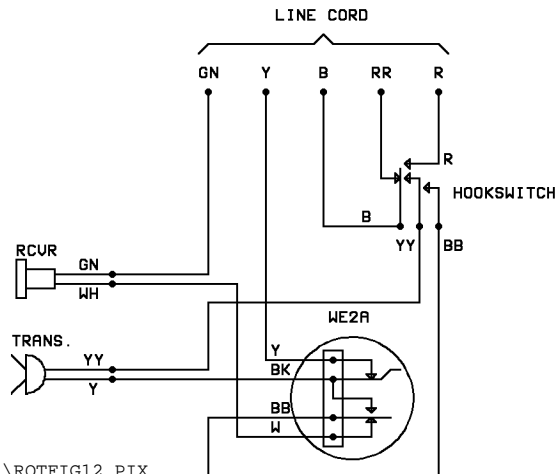
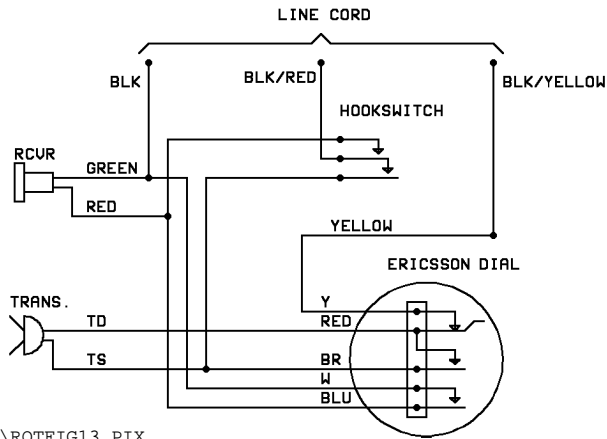

Figure 12: WE dial candlestick; use with WE 634A sidetone ringer box shown on page 8 by omitting leads "B" and "RR"

\ROTFIG12.PIX



\ROTFIG13.PIX

Figure 13: Ericsson dial candlestick; use with WE 634A ringer box shown on page 8 except that "black/yellow"=Y, "black/red"=R, and "black"=GN

Figure 14: WE 202 cradle instrument, wired for sidetone circuit (use with WE 634A ringer box shown on page 8); uses WE 4H or 5H dial

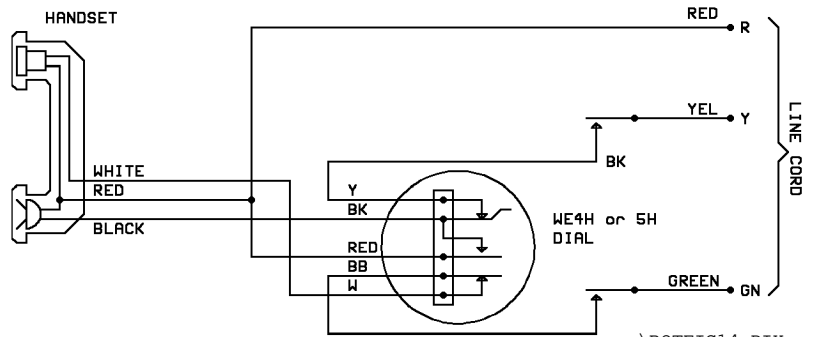

\ROTFIG14.PIX

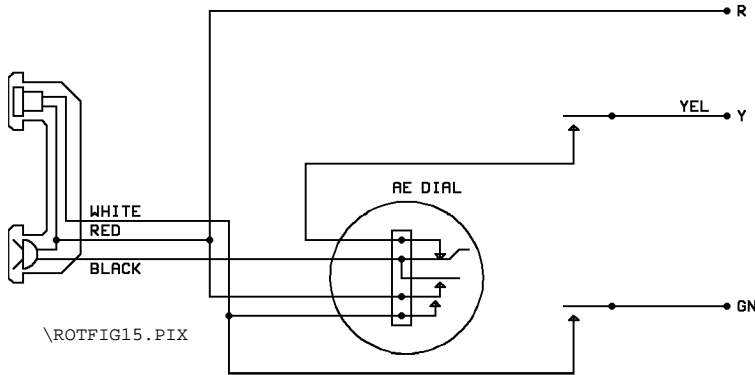

\ROTFIG15.PIX

Figure 15: WE 202 cradle set wired for sidetone circuit with AE dial; identical circuit used in AE "monophone" (use with ringer box on page 8)

Figure 16: WE candlestick instrument wired for anti-sidetone circuit (use with anti-sidetone ringer box shown on page 9). Uses WE 2A dial.

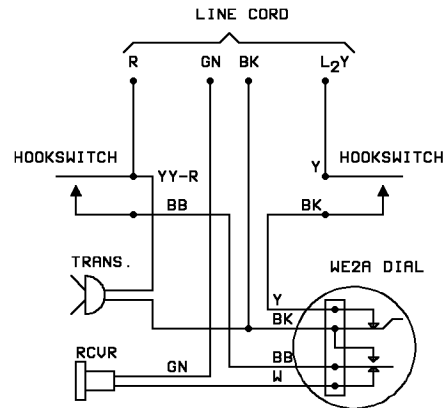

\ROTFIG16.PIX

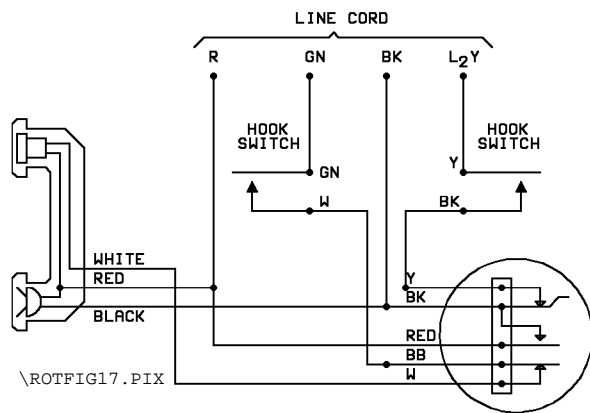

Figure 17: WE cradle set wired for anti-sidetone circuit (use with anti-sidetone ringer box shown on page 9). Uses WE 4H or 5H dial.

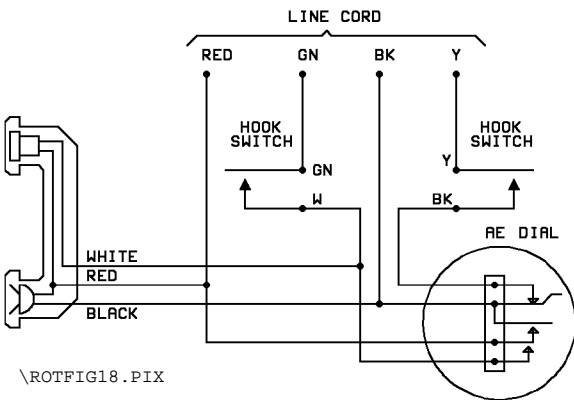

Figure 18: WE or other manufacturer's cradle instrument wired for anti-sidetone circuit, using AE dial. (Use with anti-sidetone ringer box shown on page 9)

## Restoration and troubleshooting

Several difficulties commonly occur with aged dials. Patience and ingenuity are essential in repair.

1. Bent finger wheel, striking fingerstop or frame: remove and straighten.
2. Dust and corrosion: remove with alcohol and pipe cleaners or cotton swab. The governor is particularly sensitive to the slightest amount of dirt. Lightly oil metal parts (except governor).
3. Loss of spring tension on finger wheel shaft: this is provided by a coil spring wound around the shaft itself in the center of the dial. The problem is rectified by adding one or a few turns to the spring. On WE dials this is done from the front, removing the fingerwheel, number plate, and finally the plate which stops the finger wheel shaft from rotating more than one turn. With this latter removed, the shaft can be rotated to provide additional tension. On AE dials tension is increased from the rear by removing the end of the coil spring from the slit in the shaft, twisting, and reinserting.

In any case, take care not to release the coil spring and be certain to clear any impediments to free movement before increasing spring tension.

4. Misadjusted contact springs: this may occur from loss of fiber or rubber pushers (which must be replaced or refabricated) or loss of tension (which must be added by bending springs carefully).

Pulsing springs: observe operation while finger wheel is rotated: they should open and close a number of times corresponding to the number pulled, ending *closed*.

Shunting springs: they should shift just as the dial is rotated, and remain operated for the entire time the pulsing springs pulse. They should return to their normal position just as the finger wheel returns to rest.

#### ***Conversion of manual to dial***

Manual instruments having a dial blank may easily be converted to dial operation by adding a dial, using the appropriate circuit shown on the preceding pages, depending on the hookswitch configuration, whether handset or separate transmitter and receiver, and whether sidetone or anti-sidetone.

Instruments without physical provision for a dial may also be converted to dial use, by mounting the dial on an appropriate home-made adapter. Alternatively if one does not wish to alter the original condition of an old telephone, the dial can be mounted separately in a wood or metal case, and connected to the instrument by a four-conductor line cord.

"Pinging" of the bell when dialing can be overcome by reversing the bell leads, or by increasing the spring tension on the clapper.

## CONVERTING MAGNETO INSTRUMENTS TO COMMON BATTERY MANUAL OR DIAL

Fortunately magneto instruments can easily be converted to common battery circuitry, so as to be functional as well as attractive. Circuit differences necessitate rewiring, however, and the following parts must be purchased for each conversion: sidetone induction coil; condenser (if magneto phone does not have one--some did); and a dial if dialing out is desired in addition to receiving calls. The following steps should be performed.

1. Disconnect the magneto and remove magneto connecting wires to prevent accidental shorts.
2. Check receiver for satisfactory operation and if substandard, replace as noted in section on magneto instruments. (This may not be apparent until unit is tested in operation.)
3. Check the transmitter for satisfactory operation, and if substandard replace as noted in section on magneto instruments. (This also may not be apparent until tested in operation.)
4. An important difference between magneto and common battery circuits is that in the latter all accessible metal components are isolated electrically from the internal wiring. In magneto instruments, on the other hand, magneto handles, metal handsets, and other metal parts may be connected to the circuit. Since this could result in a dangerous or at least annoying shock when adapted to common battery use, it is important to isolate all components from the internal wiring. This can be checked by measuring resistance from the component in question (e.g. two transmitter terminals) to the exposed metal parts (e.g. transmitter arm, metal handset). It should be open (infinity); if not, the part must be insulated by remounting to eliminate contact (use ingenuity).

This problem will be regularly experienced with European "French" handsets where one transmitter lead is connected to the metal handset frame. In this case it is necessary to replace the transmitter with a small capsule (e.g. the N-1) with both connections isolated.

5. A magneto induction coil uses a different turns ratio between primary and secondary than a common battery induction coil, resulting in poor volume if used. Consequently a common battery induction coil, such as the WE 46B, must be used.

Anti-sidetone induction coils cannot be used with the commonest hookswitch configuration in magneto instruments and so are not considered here to simplify the discussion.

6. Some magneto instruments have one leaf of the hookswitch in electrical contact with the exposed stirrup, permitting a shock as noted above. If

your phone has such a hookswitch, you must improvise a way to insulate the contact springs from the stirrup. One approach is suggested at right.

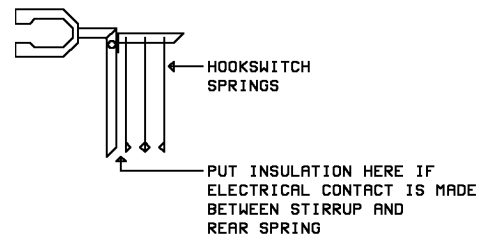

\ROTFIG20.PIX

7. Most magneto instruments do not use a capacitor, and one must be included for common battery use. If the magneto instrument has one but it is not clearly marked "1 mfd" or "1 MF" replace it as it might be the wrong value. Any one microfarad 200 Volt (or more) paper--not electrolytic--capacitor may be used.
8. If dial operation is desired a dial may be installed in several ways. For European-style desk phones, it may be mounted either directly on the case, or else on a separate base of wood or metal and connected to the phone by a cord. If the latter is chosen, only an AE dial with contacts as shown in Figure 15 may be used, with a four-conductor cord. (WE dials would require a five-conductor cord, not readily available.)

For magneto wallphones, the dial may be mounted in three places. First and easiest is directly on the face of the instrument, but this alters the original appearance. An alternative on "two box" phones is to hinge the top of the bottom box, with the dial easily accessible in the box, but not visible in normal use. A third possibility is to place the dial inside the case, replacing the screw-catch with a magnetic or friction kitchen-cabinet catch. The front panel of the phone may be pulled out to dial, and returned to normal position at other times.

### Circuits

Wall instruments with an acceptable hookswitch of the form  can be rewired for manual service using the circuit shown in Figure 5. When rewiring for dial use Figure 19 below, with WE 4H or 5H dial.

Magneto desk phones with handset may be rewired for manual service using the circuit shown in Figure 8, combined with the associated ringer box circuit. For dial service use Figure 14 for WE dials and Figure 15 for AE dials.

Magneto wall ringer boxes can be rewired to conform to the one shown on page 8 for use with either cradle or candlestick manual or dial instruments.

It should be noted that bells intended for magneto use will "ping" when adapted to common battery circuits, due to lack of a bias spring. If ringing is not desired simply disconnect the ringer leads and tape.

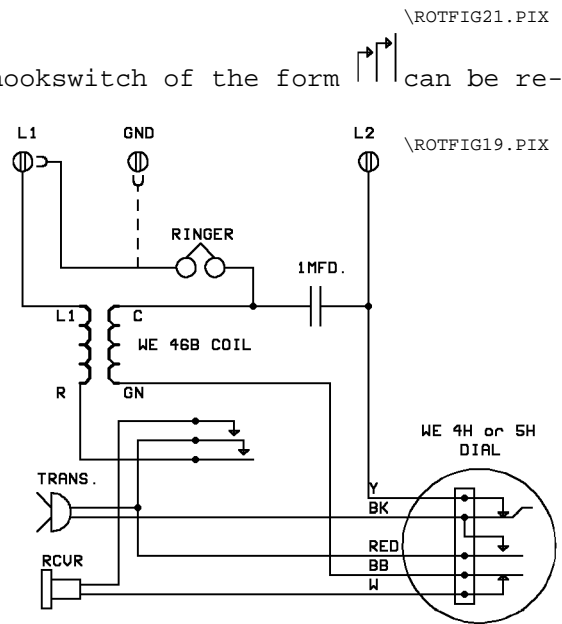

Figure 19: Suggested circuit for rewiring magneto set with three-spring hookswitch to dial service

**SUGGESTED SUPPLIERS--OLD PHONES AND PARTS**

Billard's 21710 Regnart Road Cupertino CA 95014	Tel: +1 408 252-2104 E-mail: jess97@gateway.net
Steve Hilsz 66776 East Hwy 60 Salome AZ 85348	Tel: +1 520 859-3595 URL: <a href="http://sites.netscape.net/stevehilsz/homepage">http://sites.netscape.net/ stevehilsz/homepage</a>
OldPhones.com	Tel: +1 412 371-3507 E-mail: jon@oldphones.com URL: <a href="http://www.oldphones.com">www.oldphones.com</a>
Phoneco Inc. PO Box 70 Galesville WI 54630	Tel: +1 608 582-4124 Fax: +1 608 582-4593 URL: <a href="http://www.phonecoinc.com">www.phonecoinc.com</a>
Play Things of Past 3568 West 105th Street Cleveland OH 44111	Tel: +1 216 251-3714, Fax: +1 216 251-3714 URL: <a href="http://www.olderadioparts.com">www.olderadioparts.com</a> E-mail: gbsptop@aol.com
Vintage Phones	E-mail: <a href="mailto:mail@vintagephones.com">mail@vintagephones.com</a> URL: <a href="http://www.vintagephones.com">www.vintagephones.com</a>

**SUGGESTED SUPPLIERS--NEW PHONES AND PARTS**

BECO Manufacturing Corp. PO Box 218 Germantown NY 12526	Tel: +1 518 537-6213 Fax: +1 518 537-5426 URL: <a href="http://www.becophones.com">www.becophones.com</a>
Mike Sandman 390 East Irving Park Road Roselle, IL 60172	Tel: +1 630 980-7710 E-mail: <a href="mailto:mike@sandman.com">mike@sandman.com</a> URL: <a href="http://www.sandman.com">www.sandman.com</a>
Walker Equipment 4009 Cloud Springs Road Ringgold GA 30736	Tel: +1 706 861-2212 Fax: +1 706 861-5069 URL: <a href="http://www.handset.com">www.handset.com</a>
Roanwell 180 Varick Street New York NY 10014	Tel: +1 212 989-1090 Fax: +1 212 989-3285 URL: <a href="http://www.roanwellcorp.com">www.roanwellcorp.com</a>
Telephone Engineering Co. 786 Main Street Simpson PA 18407	Tel: +1 717 282-5100

## RESOURCES

1. A. Michael Noll, *INTRODUCTION TO TELEPHONES AND TELEPHONE SYSTEMS*, second edition, Artech House, Boston and London, 1991.

Artech House  
685 Canton Street  
Norwood MA 02062

Tel: +1 781 769-9750  
Fax: +1 781 769-6334  
E-mail: [artech@artechhouse.com](mailto:artech@artechhouse.com)  
URL: [www.artech-house.com](http://www.artech-house.com)

2. Stephen J. Bigelow, *UNDERSTANDING TELEPHONE ELECTRONICS*, 3rd edition, SAMS Computer Publishing Division of Prentice Hall, Carmel IA, 1992.

Sams Technical Publishing  
5436 West 78th Street  
Indianapolis IN 46268

Tel: +1 800 428-7267  
Fax: +1 800 552-3910  
URL: [www.samswebsite.com](http://www.samswebsite.com)

3. *BLACK MAGIC! TELECOM DESIGN TRICKS*, downloadable from [www.camblab.com/lit/lit.htm](http://www.camblab.com/lit/lit.htm).

Cambridge Electronics Labs  
20 Chester Street  
Somerville MA 02144

Tel: +1 617 629-2805  
Fax: +1 617 623-1882  
E-mail: [camblab@attglobal.net](mailto:camblab@attglobal.net)

Details of operation of power, ringing and talk-battery circuits and their design.

4. "Direct Connection: Interfacing to the Telephone Network", *Application Note 102*, Compliance Engineering, 1990.

Compliance Design Inc.  
70 Codman Hill Road  
Boxborough MA 01719

Tel: +1 978 264-4668  
Fax: +1 978 263-7086  
URL: [www.etlsemko.com](http://www.etlsemko.com)

Succinct description of theory and practice of telephone instruments and system operation, signalling and interfacing; also includes regulatory compliance and safety issues.

5. *TELECOM DESIGN SOLUTIONS*, Teltone Corporation, Issue 1, Fall 1990

Teltone Inc.  
22121 20th Avenue SE  
Bothell WA 98021

Tel: +1 800 426-3926  
Fax: +1 425 487-2288  
E-mail: [info@teltone.com](mailto:info@teltone.com)  
URL: [www.teltone.com](http://www.teltone.com)

Especially Application Note SC-1: "Applications for DTMF and Pulse Telephone Dialing", which provides a comprehensive overview of switched network interface standards, methods, and typical circuits.

**=REGISTRATION TO RECEIVE LITERATURE UPDATE INFORMATION=**

Submit by post, facsimile or e-mail to:

Cambridge Electronics Laboratories  
20 Chester Street, Somerville MA 02144-3005  
Telefax +1 617 623-1882 camblab@attglobal.net

Name \_\_\_\_\_

Address \_\_\_\_\_

City \_\_\_\_\_ State/province \_\_\_\_\_ Postcode \_\_\_\_\_

Telephone (include area code) \_\_\_\_\_

Facsimile (include area code) \_\_\_\_\_

E-mail \_\_\_\_\_

Registrant's area of interest \_\_\_\_\_

\_\_\_\_\_

\_\_\_\_\_

Remark or comment \_\_\_\_\_

\_\_\_\_\_